

Secc.X

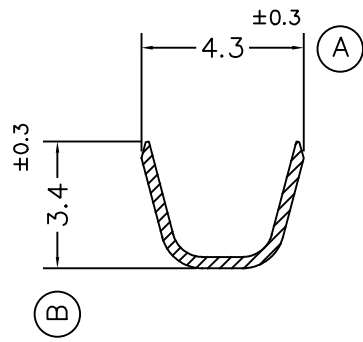

Secc.Y

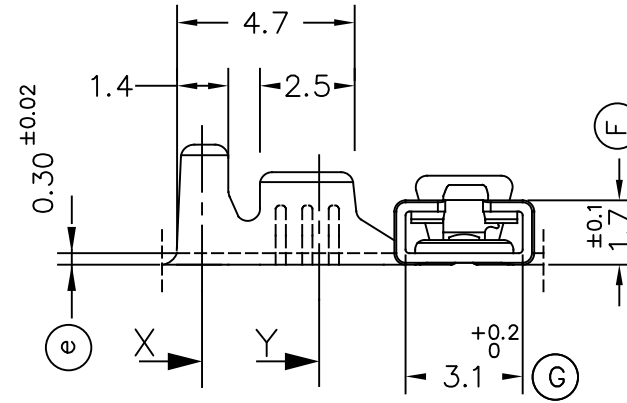
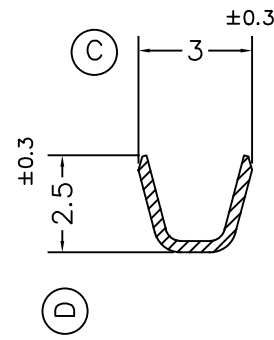

FORMA DE SUMINISTRO

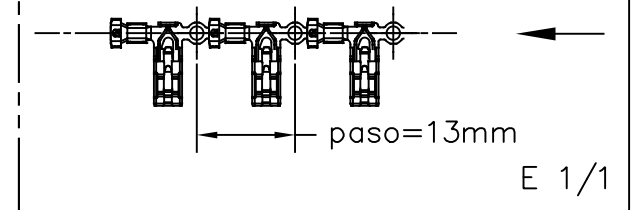

Secc.Z-Z

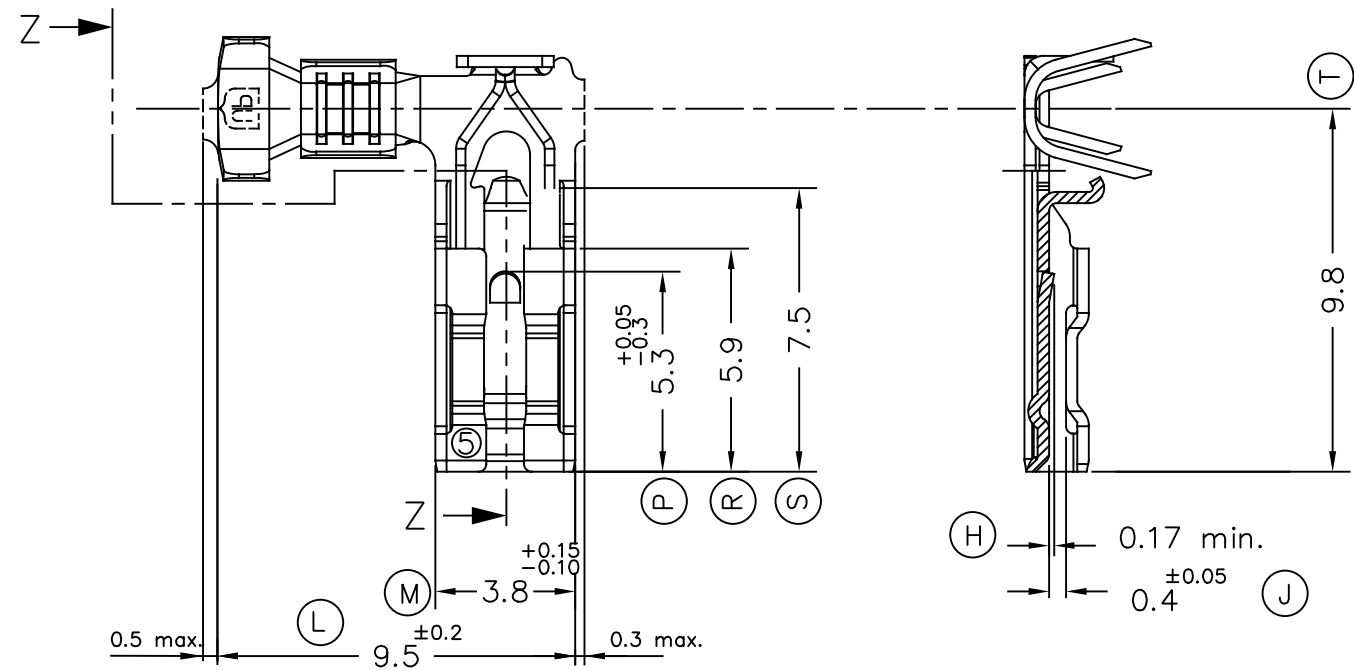

							05	Modifica. cota H (OR)	26/07/21
							04	Cota H	04/11/19
							03	Mdf.cotas	15/05/18
5706.24	Pre-Ni	Acero	0.5÷1.0mm ²	1.8÷2.5mm.	2.8x0.5		02	Act. dim.	01/02/18
5706.01	Pre-Sn	Latón*					01	Mats.	21/09/17
5706.00	Natural	CuZn30					00	1ª Edición	03/11/15
Referencias	Acabados	Material	Sección Conductor	∅ Aislante	Para Macho		Rev.	Modificación	Fecha
		TERMINAL HEMBRA Serie 2.8 UP-TPSEK3							
DIBUJADO	JCS	03/11/15				FORMATO		A3h	
CONTROL	FAT	03/11/15	NORMAS MATERIALES EN 1654 *	NORMAS DIMENSIONALES Especiales	TOLERANCIAS GENERALES ±0.2 ±2°	NOMBRE		PT5706 "c"	
ESCALA	5/1					REF.		5706.xx	