

FORMA DE SUMINISTRO

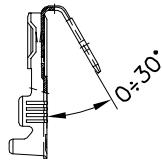

UNITARIO

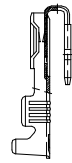

CADENA

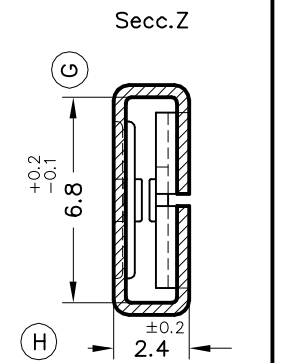
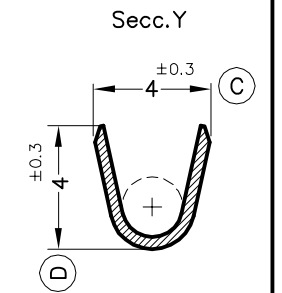
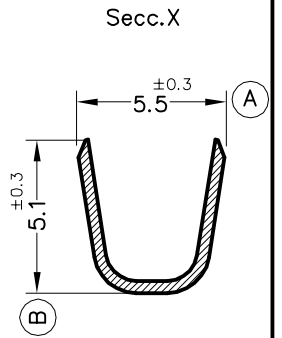
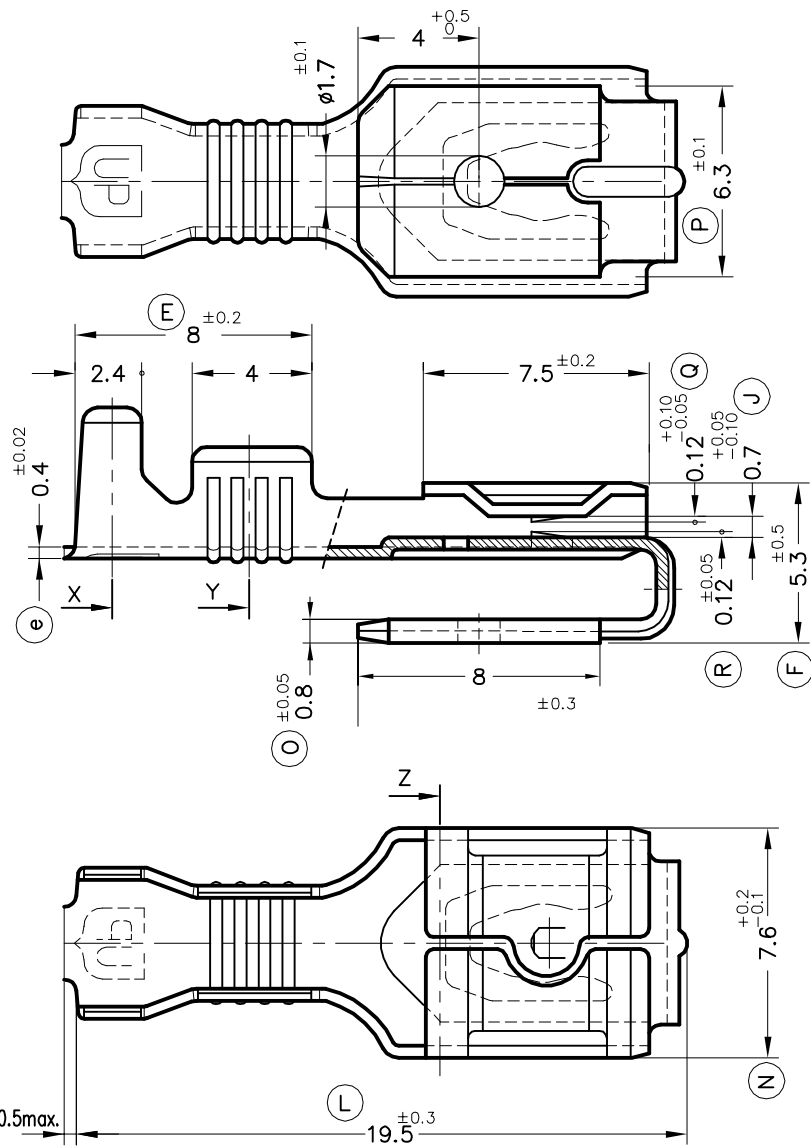
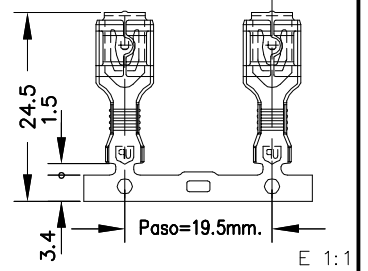

5236.31	Pre-Estañado	Bronce*										
5236.30	Natural	CuSn6										
5236.24	Pre-Niq.	Acero	$1 \div 2.5mm^2$	$2.7 \div 4.3mm.$	6.3×0.8							
5236.01	Pre-Estañado	Latón*							01	Añadir detalle suministro unitario	04/03/13	
5236.00	Natural	CuZn30							00	1ª Edición	10/07/07	
Referencias	Acabados	Material	Sección Conductor	ϕ Aislante	Para Macho	A	B	C	D	Rev.	Modificación	Fecha

<p>ESCUBEDO Especialitats Elèctriques Escubedo S.A.</p>			<p>TERMINAL MIXTO MACHO Serie 6.3 Baja Inserción</p>						<p>Terminales</p> <p>UP Electricos</p>		
DIBUJADO	JCS	04/08/06							FORMATO		A4v
CONTROL	FAT	04/08/06	NORMAS MATERIALES		NORMAS DIMENSIONALES		TOLERANCIAS GENERALES		NOMBRE		
ESCALA	4/1		EN1654*		Especiales		$\pm 0.2 \pm 2^\circ$		REF. 5236.xx		