

Secc. X-X'

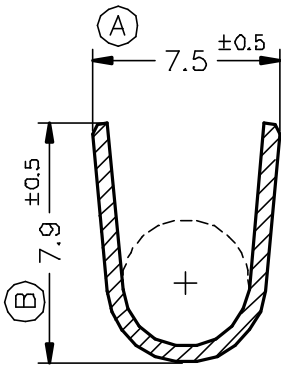

FORMA DE SUMINISTRO

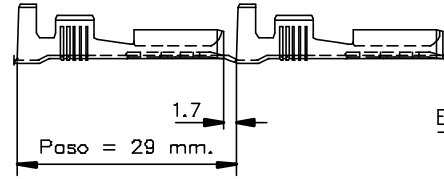

Secc. Z-Z'

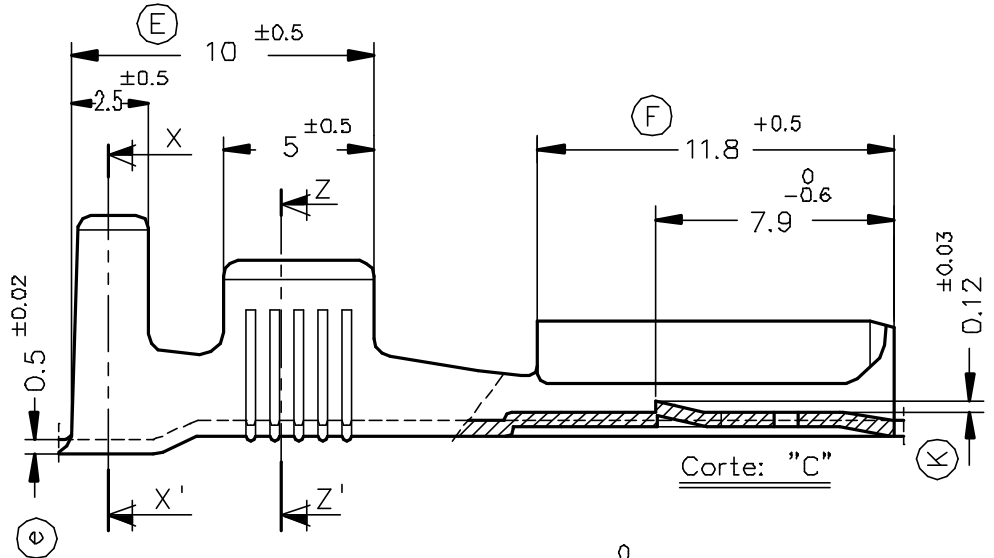
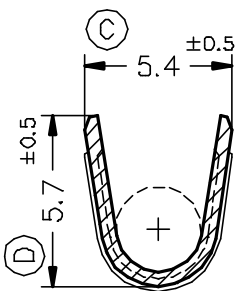

Secc. Y-Y'

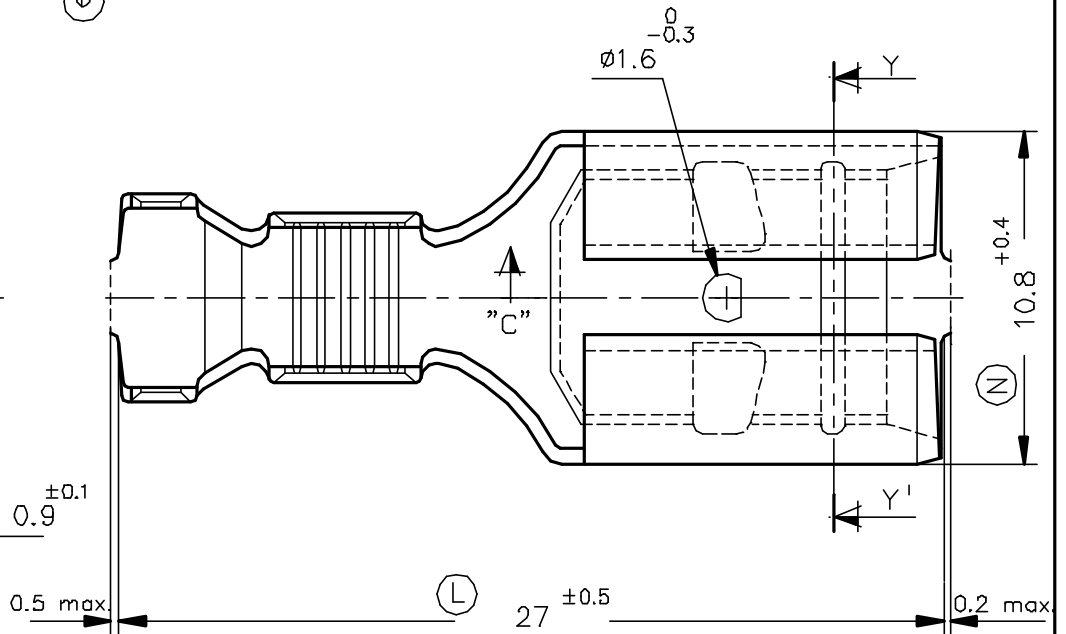
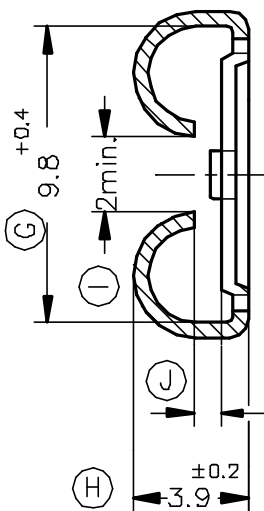

4482.32	Estañado	Bronce	4 ÷ 6mm ²	3.8÷5.1mm.	9.5x1.2															
4482.30	Natural	CuSn6																		
4482.02	Estañado	Latón																		
4482.00	Natural	CuZn30																		
Referencias	Acabados	Material	Sección Conductor	φ Aislante	Para Macho	A	B	C	D	Rev.	Modificación	Fecha								



TERMINAL HEMBRA Serie 9.5



DIBUJADO	I. Gasull	06/10/98	NORMAS MATERIALES DIN17670	NORMAS DIMENSIONALES Especiales	TOLERANCIAS GENERALES ±0.2 ±2°	FORMATO	A4v
CONTROL	F.Adamuz	06/10/98				NOMBRE	PT4482 "c"
ESCALA	4/1		REF. 4482.xx				