

FORMA DE SUMINISTRO

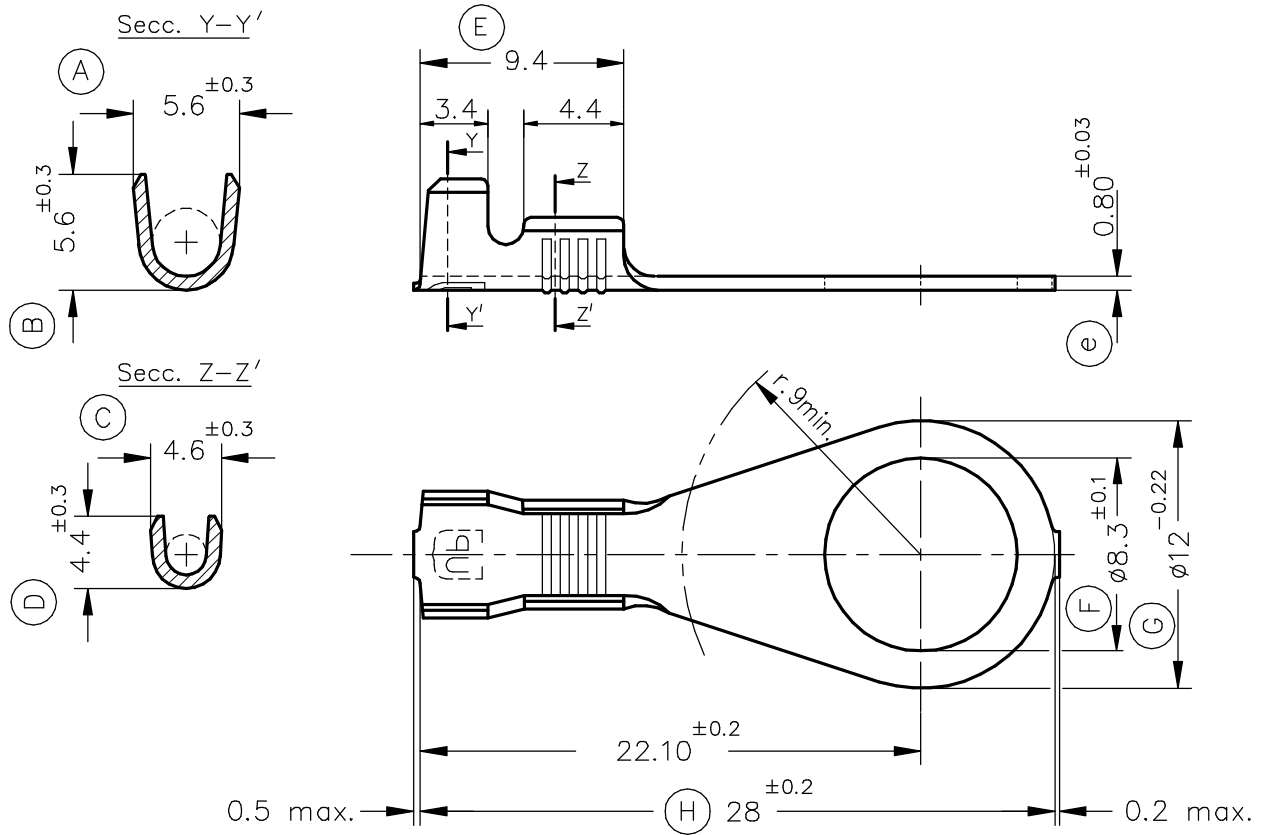
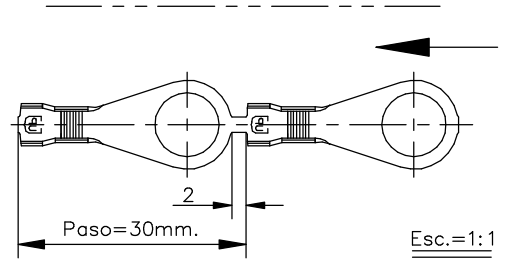

3576.32	Estañado	Bronce*	1 ± 2.5mm ²	3 ± 4.3mm.																
3576.30	Natural	CuSn6																		
3576.02	Estañado	Latón*																		
3576.00	Natural	CuZn30																		
Referencias	Acabados	Material	Sección Conductor	Ø Aislante	J	A	B	C	D	Rev.	Modificación	Fecha								

<p>ESCUBEDO Especialitats Elèctriques Escubedo S.A.</p>			<p>TERMINAL PARA TORNILLO Ø12 A8-2.5</p>						<p>Terminales Electricos</p>		
DIBUJADO	F.Adamuz	10/10/94							FORMATO A4v		
CONTROL	F.Adamuz	10/10/94	NORMAS MATERIALES * EN1654		NORMAS DIMENSIONALES Especiales		TOLERANCIAS GENERALES ±0.2 ±2°		NOMBRE PT3576 "c"		
ESCALA	3/1								REF. 3576.xx		