

7553.**

MALES FOR CONNECTOR - UP-LOK2 TERMINALS



Description Solid pin – secondary lock- double wire

Wire section range 3.00 – 5.00 mm² (AWG 12)

Max. Insulator Ø 5.0 mm

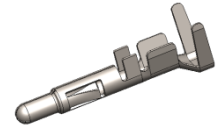

Materials, Temperature & Contact resistance

Part nr.	Material	Finishing	Max. Temp. (C°)
7553.01	Brass	Pre-tin plated	120

Material thickness 0.32 mm

Application tool MN7553

Wire striping length 3.1 (±0.5) mm

Crimping parameters & Pull out force

Wire section (mm ² ±10%)	Conductor (mm)		Insulator (mm)		Pull-out force (N)
	Height (±0.05)	Width (measured)	Height (Max.)	Width (Max.)	
1.50+1.50	2.15	2.74	2.9 Max	4.8 Max	>200
1.00+2.50	2.25	2.76	2.9 Max	4.8 Max	>100
1.50+2.50	2.30	2.76	2.9 Max	4.8 Max	>160
2.50+2.50	2.15	2.97	2.9 Max	4.8 Max	>200

Note: Values only valid for the application tool specified. The insulator width is only indicative as they depend of the insulation properties

Packaging 3500 Pieces on 25 mm cardboard reel, 15 mm terminal chain pitch

7553.**

MALES FOR CONNECTOR - UP-LOK2 TERMINALS



Drawing

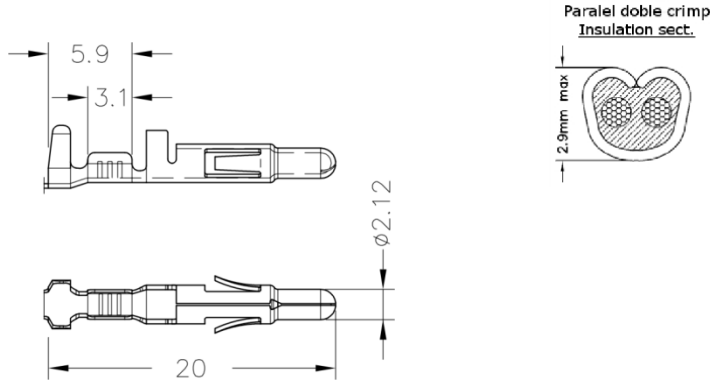

Approvals

- RoHS Compliant



Connectors Compatibility

Material		Color	
Reference	Material	Reference	Color
222**1*	PA66V2	222***0	Natural
222**3*	PA6/66V0	222**11	White
222**4*	PA6/66V2750N	222***2	Yellow
222**5*	PA646STY	222***3	Red
222**6*	PA66V0750NF	222***4	Green
222**9*	PBT	222***5	Black
-	-	222***6	Blue
-	-	222***7	Brown
-	-	222***8	Grey
-	-	222***9	Purple
-	-	222***A	Pink
-	-	222***B	Orange

222-X-X-X-X

Color

Material

Ways Number

4 Female Connector

5 Male Connector

Note: For more information ask: info@escubedo.com

Disclaimer

Data obtained from Escubedo Laboratory essays, using own methodology, cabling, equipment and original crimping tools, done in laboratory conditions and following the indicated standards, errors and omissions excepted. This document has no contractual meaning and it is publicised only for informative purposes. It can be changed without prior notice. The end customer has the sole responsibility to check these characteristics in its environment and with its own components, manufacturing methods and equipment. See also the full range product overview if available. For further information please visit our web site or contact

Rev. Nr.	Modification	Date	Created/Revised	Approved
1	Creation	22/12/2014	D.Martinez/E.Roura	Joan carles Sanchez
2	Update	17/02/2015	D.Martinez/E.Roura	Joan carles Sanchez
3	Add Connectors Compatibility & Update	29/11/2016	D.Martinez/E.Roura	X.Menac