

6452.**



2,3 (.090) UP-NIP TABS FOR CONNECTOR

Description Tab for connector 2.3x0.65mm.

Wire section range 0.5-1.25 mm² (AWG 20 - 16)

Tongue thickness 0.65 mm

Max. Insulator Ø SEAL - 3.0 mm



Materials & Temperature

Part nr.	Material	Finishing	Max. Temp. (C°)
6452.00	Brass	Natural	110
6452.01	Brass	Pre-tin plated	120
6452.30	Bronze	Natural	120
6452.31	Bronze	Pre-tin plated	130

Material thickness 0.3 mm

Max. Rated current

Maximum Current values.

Values of the table show the recommended maximum current values, limited by the cross section of the cable used. These maximum values also depend on the ambient temperature, and can be reduced depending on the working conditions. For more precise information about the maximum rating current applicable in each case, consult the "Temperature Rise" and "De-rating" curves.

Wire section (mm ²)	Current (A)
0.50	6
0.75	8
1.00	8
1.25	8

Insertion/Withdrawal forces

1st. Insertion	10 ÷ 15 N Max.
1st. Withdrawal	5 ÷ 15 N Max.

Note: Insertion and withdrawal forces valid for 4452.** tab.

Application tool MN6452

Wire stripping length 4.7 (±0.5) mm

Crimping parameters & Pull out force

Wire section (mm ² ±10%)	Conductor (mm)		Insulator	Pull-out force (N)
	Height (±0.05)	Width (measured)		
Nominal			According to used SEAL	Min.
0.50	1.20	2.04		70
0.75	1.30	2.04		90
1.00	1.35	2.05		120
1.25	1.45	2.06		120

Note: Values only valid for the application tool specified. The insulator width is only indicative as they depend of the insulation properties

Packaging 7000 Pieces on 25 mm cardboard reel, 10.5 mm terminal chain pitch

6452.**

2,3 (.090) UP-NIP TABS FOR CONNECTOR



Drawing

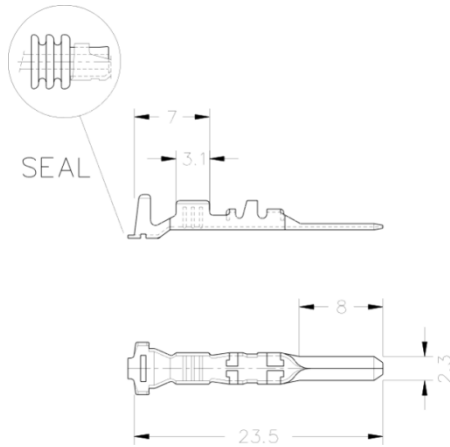

Connectors Compatibility

Note: For info ask: info@escubedo.com

Approvals

RoHS Copliant	✓ RoHS
---------------	-----------

Note: (T.B.D.) To be determined

Disclaimer

Data obtained from Escubedo Laboratory essays, using own methodology, cablings, equipment and original crimping tools, done in laboratory conditions and following the indicated standards, errors and omissions excepted. This document has no contractual meaning and it is publicised only for informative purposes. It can be changed without prior notice. The end customer has the sole responsibility to check these characteristics in its environment and with its own components, manufacturing methods and equipment. See also the full range product overview if available. For further information please visit our web site or contact us.

Rev. Nr.	Modification	Date	Created/Revised	Approved
4	Update	12/05/2017	D.Martinez / E.Roura	X.Menac
3	Standard max. Temp. change	25/03/2011	David Martinez	Joan Carles Sanchez
2	Crimp icon addition	01/04/2004	Marc Garangou	Luis Barea
1	Creation	19/12/2003	Marc Garangou	Luis Barea