



**4934.\*\***  
**6.3 (.250) TYPE SERIES · RECEPTACLES**



**Specification** Basic self locking under TP design

**For male (mm)** 6,3x0,8

**Wire size mm<sup>2</sup> (AWG)** 2,5-5 (14-10)

**Ø Insulation (mm)** 3,6-5

**Materials, temperature and contact resistance**

Part nr.	Material	Finishing	Max. Temp. (°C)
4934.00	Brass	Natural	110
4934.01	Brass	Pre-tin-plated	120
4934.02	Brass	Tin plated	120
4934.24	Steel	Nickel-plated	300
4934.30	Bronze	Natural	120
4934.31	Bronze	Pre-tin-plated	130
4934.32	Bronze	Tin plated	130
4934.70	German Silver	Natural	210

**Material thickness (mm)** 0,4

**Max. rated current**

Wire section	4934.00 / 01 / 02 / 24 / 30 / 31 / 32 / 70
2.50 mm <sup>2</sup>	20A

**Insertion / Withdrawal forces**

	4934.00 / 01 / 02 / 30 / 31 / 32	4934.24 / 70
1st Insertion (max)	35N <sup>1</sup>	35N <sup>1</sup>
1st Withdrawal (min, locking enabled)	90N <sup>1</sup>	70N <sup>1</sup>

<sup>1</sup> Valid for Natural Brass Tab

**Application tool** MN4834

**Wire strip length** 5.5 (±0.5) mm

**Crimping parameters & pull out force**

Wire section (±10%)	Conductor 		Insulator	Pull-out force (N)
	Height (mm)	Width (mm)	Width (mm)	
1.50 + 1.50 mm <sup>2</sup>	1.95 (±0.05)	4.05 (±0.05)	5.52 (±0.10)	(150N @ 60s) + (150N @ 60s)
2.50 mm <sup>2</sup>	1.85 (±0.05)	4.05 (±0.05)	5.52 (±0.10)	230N @ 60s

Values only valid for the application tool specified upwards. The insulator widths are only indicative as they are dependent on the sheath thickness of the wire used.

**Winding number** 6000

**Approved regulations**

Part nr.	Approval	Standard	File	Certified framework
4934.00	UL	UL 310	E211727	AWG 14-10 (41-105 Stranded Cu) / MN4934
4934.01	UL	UL 310	E211727	AWG 14-10 (41-105 Stranded Cu) / MN4934
4934.24	UL	UL 310	E211727	AWG 14-14 (41-41 Stranded Cu) / MN4934

**Approvals**





**4934.\*\***

**6.3 (.250) TYPE SERIES · RECEPTACLES**



**Drawing**

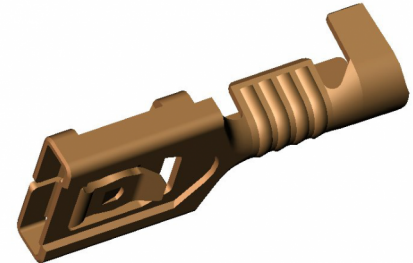
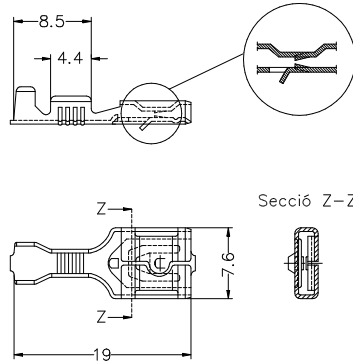

**Disclaimer**

Data obtained from Escubedo Laboratory essays, using own methodology, cablings, equipment and original crimping tools, done in laboratory conditions and following the indicated standards, errors and omissions excepted. This document has no contractual meaning and it is publicised only for informative purposes. It can be changed without prior notice. The end customer has the sole responsibility to check these characteristics in its environment and with its own components, manufacturing methods and equipment. See also the full range product overview if available. For further information please visit our web site or contact us

Rev. Nr.	Concept	Date	Created/Revised	Approved
A1	Datasheet generated automatically [A1]	2019-02-20	Laboratory Dept.	E. Roura

Especialitats Elèctriques Escubedo S.A.U. · Ctra. de Girona-Olot Km. 35,5 · 17843 Riudellots de la Creu · Girona · Spain  
Tel.: 34 972 171 706 · Fax: +34 972 171 714 · [info@escubedo.com](mailto:info@escubedo.com) · [www.escubedo.com](http://www.escubedo.com)