



**4813.\*\***  
**4.8 (.187) TYPE SERIES · RECEPTACLES**



**Specification** Low insertion

**For male (mm)** 4,8x0,5

**Wire size mm<sup>2</sup> (AWG)** 0,5-1 (20-18)

**Ø Insulation (mm)** 1,8-2,5

**Materials, temperature and contact resistance**

Part nr.	Material	Finishing	Max. Temp. (°C)	Contact Resist (mΩ)
4813.00	Brass	Natural	110	0.95
4813.01	Brass	Pre-tin-plated	120	0.70
4813.24	Steel	Nickel-plated	300	(T.B.D.)
4813.30	Bronze	Natural	120	(T.B.D.)
4813.31	Bronze	Pre-tin-plated	130	(T.B.D.)

**Material thickness (mm)** 0,35

**Max. rated current**

Wire section	4813.00 / 01 / 24 / 30 / 31
0.50 mm <sup>2</sup>	8A
0.75 mm <sup>2</sup>	10A
1.00 mm <sup>2</sup>	12A

**Insertion / Withdrawal forces**

	4813.00 / 01 / 24 / 30 / 31
1st Insertion (max)	25N <sup>1</sup>
1st Withdrawal (max)	50N <sup>1</sup>
1st Withdrawal (min)	22N <sup>1</sup>
6th Withdrawal (min)	13N <sup>1</sup>

<sup>1</sup> Valid for Natural Brass Tab

**Application tool** MN4815

**Wire strip length** 4.4 (±0.5) mm

**Crimping parameters & pull out force**

Wire section (±10%)	Conductor 		Insulator	Pull-out force (N)
	Height (mm)	Width (mm)	Width (mm)	
0.50 mm <sup>2</sup>	1.30 (±0.03)	2.11 (±0.03)	3.15 (±0.10)	56N @ 60s
0.75 mm <sup>2</sup>	1.40 (±0.05)	2.13 (±0.05)	3.15 (±0.10)	84N @ 60s
1.00 mm <sup>2</sup>	1.50 (±0.05)	2.13 (±0.05)	3.17 (±0.10)	108N @ 60s

Values only valid for the application tool specified upwards. The insulator widths are only indicative as they are dependent on the sheath thickness of the wire used.

**Winding number** 10000

**Compatible connectors** 24814\*\*

**Approved regulations**

Part nr.	Approval	Standard	File	Certified framework
4813.00	UL	UL 310	E211727	AWG 20-18 (10-16 Stranded Cu) / MN4813
4813.01	UL	UL 310	E211727	AWG 20-18 (10-16 Stranded Cu) / MN4813
4813.24	UL	UL 310	E211727	AWG 20-18 (10-16 Stranded Cu) / MN4813



**4813.\*\***  
**4.8 (.187) TYPE SERIES · RECEPTACLES**



**Approvals**



**Drawing**

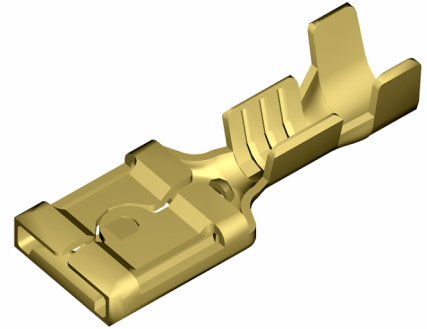
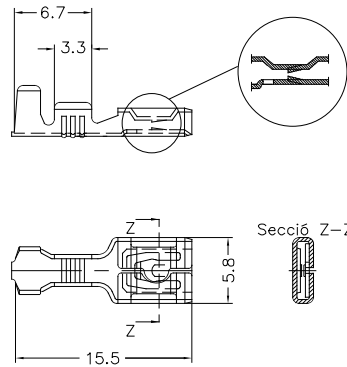

(T.B.D.): To be determined

**Disclaimer**

Data obtained from Escubedo Laboratory essays, using own methodology, cablings, equipment and original crimping tools, done in laboratory conditions and following the indicated standards, errors and omissions excepted. This document has no contractual meaning and it is publiscised only for informative purposes. It can be changed without prior notice. The end customer has the sole responsibility to check these characteristics in its environment and with its own components, manufacturing methods and equipment. See also the full range product overview if available. For further information please visit our web site or contact us

Rev. Nr.	Concept	Date	Created/Revised	Approved
A2	Update [Contact resistance]	2019-02-27	Laboratory Dept.	E. Roura
A1	Datasheet generated automatically [A1]	2019-02-12	Laboratory Dept.	E. Roura