

3417.** RING TERMINALS · WITH INSULATION SUPPORT



Specification 9.5 mm Plate

Ø (mm) 4,3

Wire size mm² (AWG) 1-2,5 (18-14)

Ø Insulation (mm) 3-4,3

Materials, temperature and contact resistance

Part nr.	Material	Finishing	Max. Temp. (°C)
3417.00	Brass	Natural	110
3417.02	Brass	Tin plated	120
3417.30	Bronze	Natural	120
3417.32	Bronze	Tin plated	130

Material thickness (mm) 0,6

Application tool MN3417

Wire strip length 6.0 (±0.5) mm

Crimping parameters & pull out force

Wire section (±10%)	Conductor		Insulator	Pull-out force (N)
	Height (mm)	Width (mm)		
1.00 mm ²	2.00 (±0.05)	3.25 (±0.05)	4.47 (±0.10)	108N @ 60s
1.50 mm ²	2.15 (±0.05)	3.28 (±0.05)	4.52 (±0.10)	150N @ 60s
2.00 mm ²	2.25 (±0.05)	3.30 (±0.05)	4.54 (±0.10)	150N @ 60s
2.50 mm ²	2.35 (±0.05)	3.31 (±0.05)	4.54 (±0.10)	230N @ 60s

Values only valid for the application tool specified upwards. The insulator widths are only indicative as they are dependent on the sheath thickness of the wire used.

Winding number 6000

Approved regulations

Part nr.	Approval	Standard	File	Certified framework
3417.00	UL	UL 486A-486B	E232316	AWG 18-14 (16-41 Stranded Cu) / MN3417
3417.02	UL	UL 486A-486B	E232316	AWG 18-14 (16-41 Stranded Cu) / MN3417

Approvals



Drawing

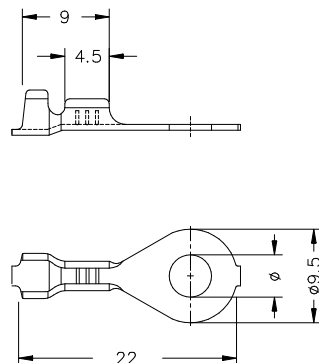

3417.**
RING TERMINALS · WITH INSULATION SUPPORT**Disclaimer**

Data obtained from Escubedo Laboratory essays, using own methodology, cablings, equipment and original crimping tools, done in laboratory conditions and following the indicated standards, errors and omissions excepted. This document has no contractual meaning and it is publicised only for informative purposes. It can be changed without prior notice. The end customer has the sole responsibility to check these characteristics in its environment and with its own components, manufacturing methods and equipment. See also the full range product overview if available. For further information please visit our web site or contact us

Rev. Nr.	Concept	Date	Created/Revised	Approved
A3	Crimping parameters changed	2024-02-23	E. Roura (Laboratory Dept.)	E. Turon (Engineering Dept.)
A2	Change company name and logo	2021-10-21	Laboratory Dept.	E. Roura
A1	Datasheet generated automatically [A1]	2018-10-01	Laboratory Dept.	E. Roura

Escubedo Connection Systems, S.A.U. · Ctra. de Girona-Olot Km. 35,5 · 17843 Riudellots de la Creu · Girona · Spain
Tel.: 34 972 171 706 · Fax: +34 972 171 714 · info@escubedo.com · www.escubedo.com